

# ASE Broadband Source

IQ-2300



≥ 11 dBm total output power

Broad, stable spectrum

2 dB flatness over a 28 nm range

Ideal for component testing



Fiber-optic test, measurement  
and monitoring instruments

**EXFO**

# A high-power source for WDM system and component characterization

The IQ-2300 ASE Broadband Source, is a stable, high-powered, non-polarized fiber-optic source ideal for WDM filter and FBG (fiber Bragg grating) testing in the lab.

The IQ-2300 ASE Broadband Source is based on the principle of amplified spontaneous emission that uses an erbium-doped fiber pumped with a 980 nm laser diode (see Figure 1). This source is perfect for characterizing components such as filters, WDM couplers, and Bragg gratings. Its non-polarized output and very short coherence length makes it ideal for stable and repetitive insertion loss and optical return loss (ORL) measurements.



## Key Features

- Loss characterization of DWDM components
- Return loss measurement
- Noise generation for system BER testing
- Polarizer testing
- Fiber Bragg grating monitoring under stress

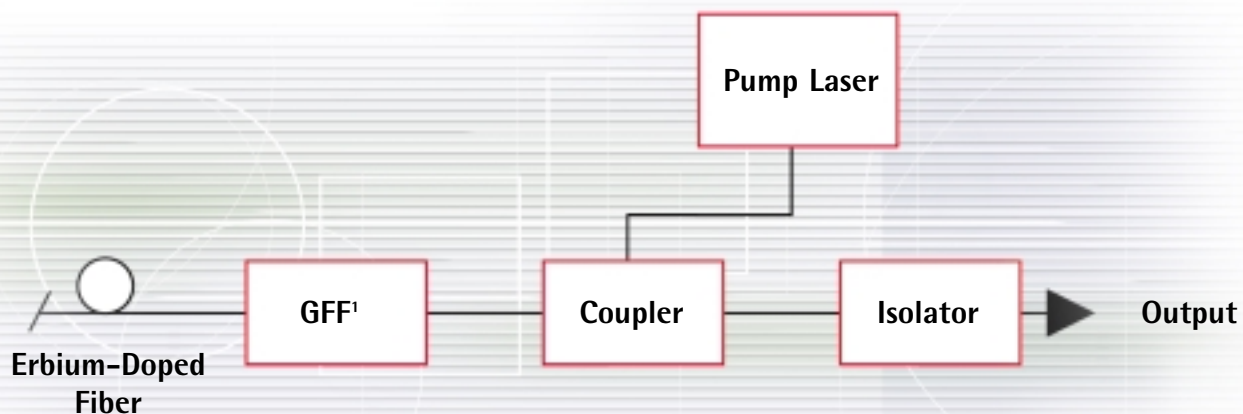
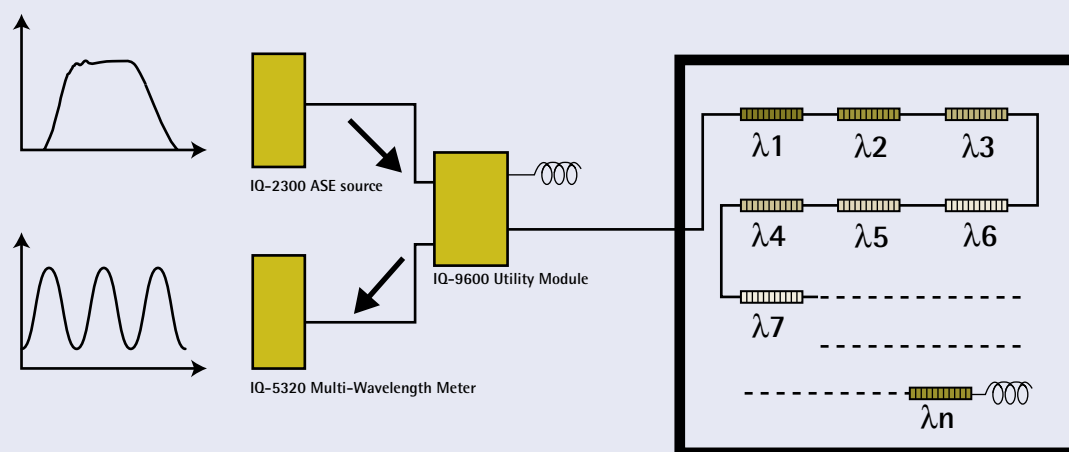

Figure 1: Internal configuration of the IQ-2300  
1. Gain Flattening Filter

## Environmental testing on fiber Bragg gratings and WDM passive components

Combine the IQ-2300 ASE Broadband Source with the IQ-5320 Multi-Wavelength Meter or WA-7600/7100 Wavemeter® Optical Channel Analyzers to perform environmental testing. This setup precisely measures drift in the central wavelength of fiber Bragg gratings undergoing temperature changes, strain, or stress-inducing conditions. To analyze the multiplexed reflected signal and obtain a resolution of 1 pm, each Bragg central wavelength should be separated by more than 0.1 nm.



Typical source power distribution  
IQ-2300 Spectrum

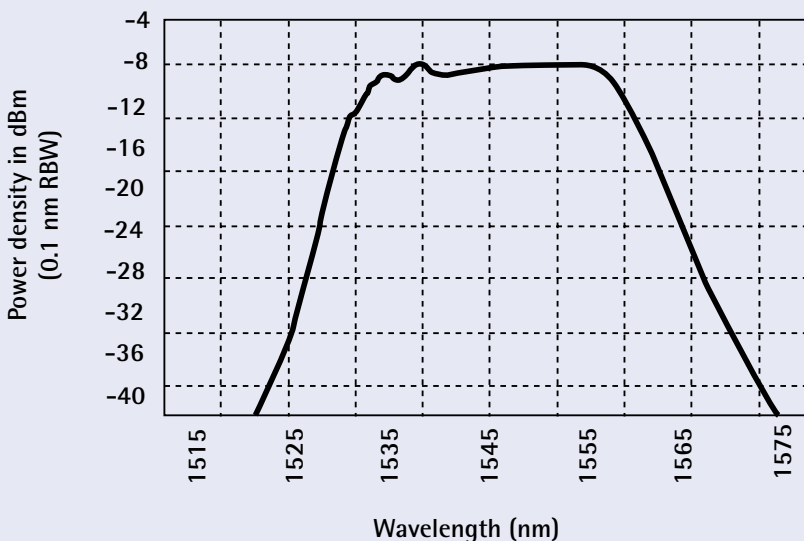

## Specifications<sup>1,2</sup>

Wavelength range (nm)	1530-1560
Wavelength span (nm) at -30 dB, typical	73
Wavelength span (nm) at -3 dB, typical	33
Output power (dBm) <sup>3</sup>	≥ 11 dBm
Spectral density (dBm/nm), typical	> -4
Spectral flatness (dB) <sup>2,3</sup>	2
Output power stability over 8 h (dB) <sup>2,3,4</sup>	± 0.05 ( $\Delta = 0.10$ )

### NOTE

1. Guaranteed within a range of 1532 to 1560 nm
2. After a warm-up of one hour
3. At 23 °C ± 1 °C.
4. The stability is expressed as ± half the difference between the maximum and minimum values during the period

## General Specifications

Size (H x W x D)	12.1 cm x 3.8 cm x 26.2 cm	(4 3/4 in x 1 1/2 in x 10 5/16 in)
Weight	0.75 kg	(1.65 lb)
Temperature	operating storage	0 °C to 40 °C -40 °C to 60 °C (32 °F to 104 °F) (-40 °F to 140 °F)
Relative humidity	0 % to 95 % non condensing	

## Software Options

OCX controls and LabVIEW drivers

## Ordering Information

### IQ-2300-96

Hybrid\* test jumpers available upon request

\* Refers to the choice of hybrid patchcord; all IQ-2300 ASE Broadband Sources are equipped with a standard E-2000/APC connector.

## Safety



### LASER SAFETY

21 CFR 1040.10 and 1040.11  
IEC 60825-1:1993+A1:1997

CLASS 3B LASER PRODUCT  
CLASS 3A LASER PRODUCT

CORPORATE HEADQUARTERS	465 Godin Avenue	Vanier (Quebec) G1M 3G7 CANADA	Tel.: 1 418 683-0211 . Fax: 1 418 683-2170
EXFO AMERICA	1201 Richardson Drive, Suite 260	Richardson TX 75080 USA	Tel.: 1 800 663-3936 . Fax: 1 972 907-2297
EXFO EUROPE	Le Dynasteur, 10/12 rue Andras Beck	92366 Meudon la Forêt Cedex FRANCE	Tel.: +33.1.40.83.85.85 . Fax: +33.1.40.83.04.42
EXFO ASIA-PACIFIC	151 Chin Swee Road, #03-29 Manhattan House	SINGAPORE 169876	Tel.: +65 333 8241 . Fax: +65 333 8242
TOLL-FREE (USA and Canada)	Tel.: 1 800 663-3936	www.exfo.com • info@exfo.com	

EXFO is certified ISO 9001 and attests to the quality of these products. This device complies with Part 15 of the FCC Rules. Operation is subject to the following two conditions: (1) this device may not cause harmful interference, and (2) this device must accept any interference received, including interference that may cause undesired operation. EXFO has made every effort to ensure that the information contained in this specification sheet is accurate. However, we accept no responsibility for any errors or omissions, and we reserve the right to modify design, characteristics and products at any time without obligation. Units of measurement in this document conform to SI standards and practices.

**Contact EXFO for prices and availability or to obtain the phone number of your local EXFO distributor.**

For the most recent version of this spec sheet, please go to the EXFO Web site at <http://www.exfo.com/support/techdocs.asp>

In case of discrepancy, the Web version takes precedence over any printed literature.

